

APPLY LUBRICANT TO ALL SEALS
PRIOR TO INSTALLATION.
DO NOT USE SILICONE TYPE LUBRICANTS.
FOR PROPER ARM MOUNTING SEE IS1505.

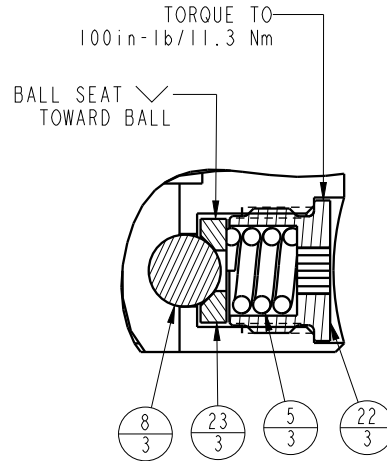
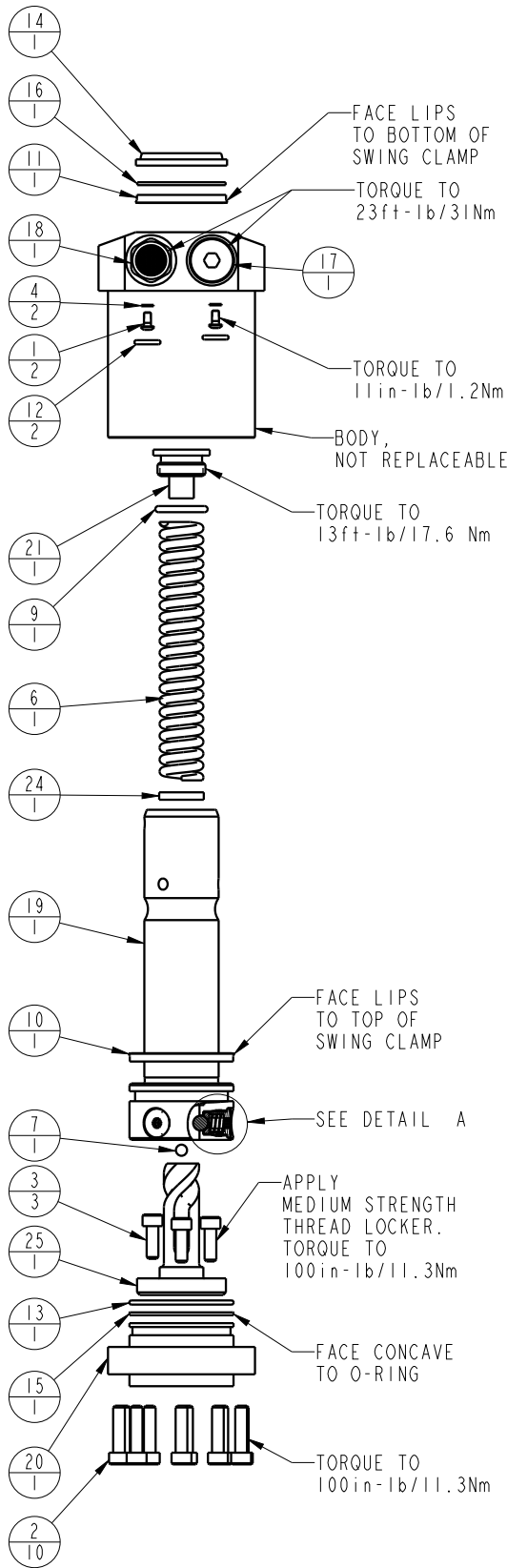

DETAIL A
SCALE 1.500

No.	QTY	PART No.	DESCRIPTION	Std. Seal Kit	FKM Seal Kit	Spring Kit
N/A	N/A	IS1505	INSTRUCTION SHEET, ARM INSTALLATION			
N/A	N/A	61704022	SPRING KIT			
N/A	N/A	6V711031	SEAL KIT, FKM			
N/A	N/A	60711031	SEAL KIT, STANDARD			
25	1	81591822	CAM, SC, LP, 5000/22KN, RH, TC			
24	1	81591302	DISK, 0.75 X .12			X
23	3	81532108	SEAT, BALL, SC, LP, TC			
22	3	81532107	RETAINER, SC, LP, TC			
21	1	81531811	PLUG, SC, LP, 5000&22KN, SA, TC			
20	1	81531809	CAP, END, SC, LP, 22KN/5000			
19	1	81511810	PLUNGER, SC, LP, 5000&22KN, SA, TC			
18	1	49001905	BREATHER, 1/4 BSPP			
17	1	43068006	PLUG, 1/4 BSPP MALE			
16	1	39054008	BU RING, (-218)	X	X	
15	1	39054007	BU RING, (-030)	X	39054021	
14	1	39053005	WIPER, SNAP-IN, (1-1/4)	X	X	
13	1	39051042	O-RING, (-030)	X	39V01021	
12	2	39050042	O-RING, (-011)	X	39051025	
11	1	39011060	SEAL, BEVEL W/HHEEL INSERT, 1-1/4 x 1/8 x 1-1/2	X	39052015	
10	1	39011055	SEAL, BEVEL, 1-9/16 x 3/32 x 1-3/4	X	39052013	
9	1	39000029	O-RING, (-115)	X	39V00029	X
8	3	23650004	BALL, TUNGSTEN-CARBIDE, 250			
7	1	23600011	BALL, STEEL, ALLOY, .187			X
6	1	23350067	SPRING, COMPRESSION			X
5	3	23350066	SPRING, COMPRESSION			
4	2	21500200	WASHER			
3	3	21500031	SHCS, M5 x 0.8 x 14, ALY			
2	10	21500022	SHCS, M5 x .8-66 x 20, ALY			
1	2	21500019	SCREW, CAP, BTNH, M3 X 6, ALY			

PARTS LIST



VEKTEK, INC.
1334 E. SIXTH AVE. P.O. BOX 625
EMPORIA, KS. 66801 U.S.A.

ASSEMBLIES AFFECTED

41462211

41462211F

SIZE
A

MPL7141

REV
C

SHEET 1 OF 1

C	5922	RELEASE	JDW	03/23/26
REV	IN ACCORDANCE WITH ECN	EFFECTIVE DATE	REVISED BY	DATE
DRW BY:	JDW	DRAWING STATUS: Released		
DATE:	6-7-11	PRODUCTION APPROVED FOR RELEASED STATUS ONLY		

FORM FEG035_PL_ASIZE, REV. B

